

## Sample Cleaner model MLN

for testing of grain samples  
for impurities



### Advantages:

1. An accurate assessment of the total consignment is obtained.
2. Price can be negotiated on the basis of a cleaned representative sample.
3. Access to all vital parts of the machine is simple.
4. Silent and vibration free operation.
5. A wide range of products can be cleaned ranging from oil seed, rape, to grain and beans etc.
6. Change of screens can be made in seconds.

### Application:

The machine is ideal for laboratory or intake facility or indeed where ever a cleaned sample of grain from a large consignment is required.

The cleaned sample also enables a more accurate moisture measurement to be obtained.



Manufacturer:

a/s rational kornservice

Gammelby Møllevvej 4  
DK-6700 Esbjerg, Denmark  
Tel.: +45 75 12 25 88  
Fax: +45 75 12 90 89  
E-mail: [rational@post10.tele.dk](mailto:rational@post10.tele.dk)

Agent:

## Principal sketch:

- A. The deawner bottom gate is closed and the preweighed grain sample is poured into the deawner.
- B. The lid is closed and the machine starts. After 20-60 secs (adjustable) the deawner discharges the sample on to the screen.
- C. The light waste is air lifted into the cyclone and precipitated into the plastic bag.
- D. The good grain is passed through the top screen and the large impurities carried over.
- E. The good grain is carried over the second screen and the sand and weed passed through the screen.
- F. The good cleaned grain feeds into the right collecting tray.
- G. The sand, small weed and light material not separated by the aspiration system feeds into the left hand tray.

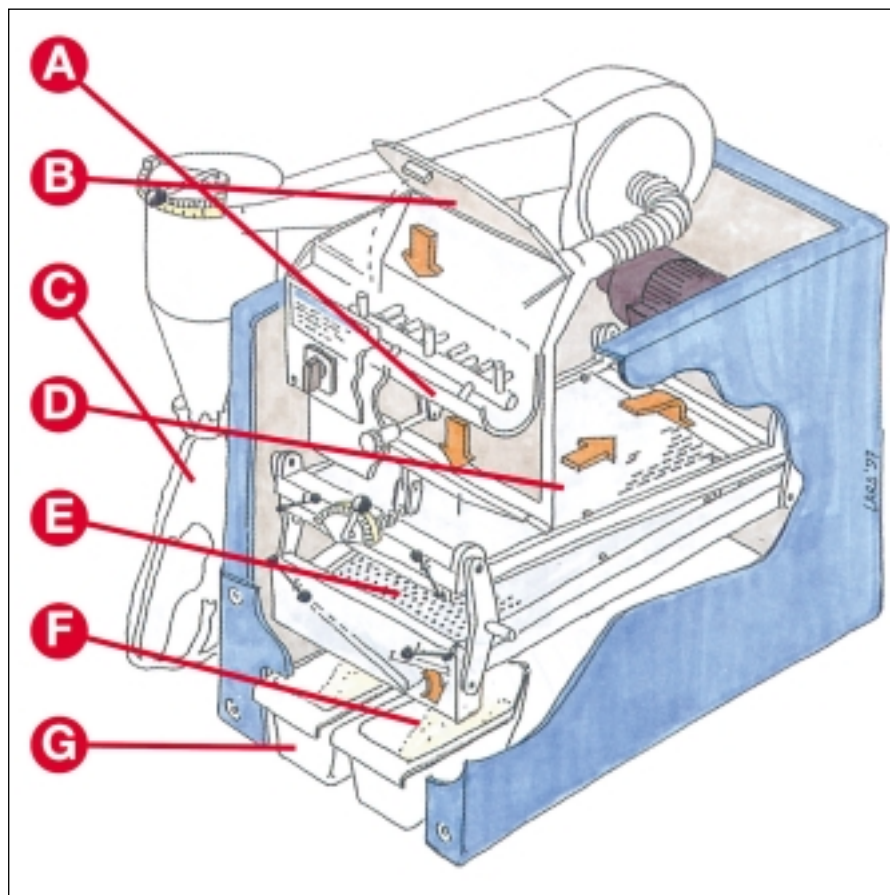

## Standard Equipment:

- 4 plastic trays of uniform weight.
- 2 metres cable.
- 2 screens.

## Extra Equipment:

- Screen plates, extension hopper, run through trays and sack holder for continuous cleaning.
- PC program for calculating percentage of impurities, fractions in gram and percentage and correction to basis 14,5 % humidity.
- Electronic balance to be connected to PC.

## Guarantee:

The cleaner is guaranteed for one year in respect of manufacturing failure. During the guarantee period defective parts will be replaced free of charge subject to those parts being returned for examination.

## Dimension Sketches:

- 1) Switch for start and manual release of deawner.
- 2) Filling cover.
- 3) Deawner outlet.
- 4) Outlet regulation.
- 5) Top screen.
- 6) Lower screen.
- 7) Fan.
- 8) Deawner.
- 9) Cyclone.
- 10) Air regulation.
- 11) Electro magnet for automatic discharge of deawner.
- 12) Plastic bag for aspirated waste
- 13) Tray for sand and non aspirated waste.
- 14) Tray for cleaned grain.
- 15) Potmeter deawner time.
- 16) Springs.

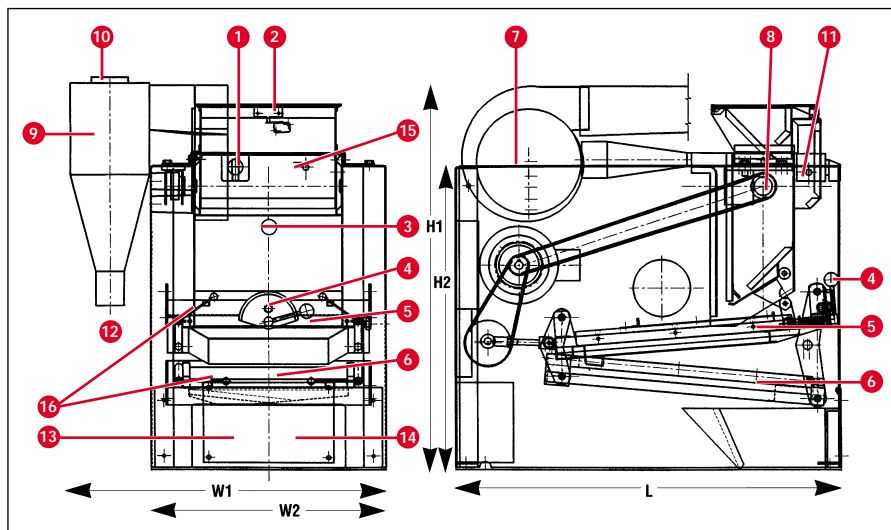

## Specifications:

Height H1	735 mm
Height H2	535 mm
Width W1	580 mm
Width W2	420 mm
Length L	680 mm
Weight	55 kg
Motor	230 V - 0.37 kW
Sample size approx.	1 kg
Sound level	82/78 dB(A)